

South East London

housing partnership

Wheelchair homes design guidelines

**Guidelines to achieve the necessary
standards for wheelchair users' dwellings**



The Guidelines are exclusively derived from the London Borough of Greenwich Wheelchair Design Site Brief – i.e. the standards contained within these guidelines and the Greenwich site brief are identical. The SE London Housing Partnership is therefore indebted to its Greenwich colleagues for their pioneering work in developing these guidelines

Document revised August 2009

The SE London Housing Partnership 'Wheelchair Homes Design Guidelines' has been devised to ensure that new affordable homes for wheelchair users are provided to the necessary standards.

The guidelines mean that property 'footprints' shall be larger than those of Lifetime Homes and relevant dwellings shall not exceed two storeys.

The plans which form part of the guidelines give the minimum size required for the various rooms in any wheelchair dwelling. They are only indicative to show how the size was calculated. Where rooms in the dwelling are combined, such as the living and dining rooms, then the minimum space requirements for the individual rooms will be required to be added together.

It is recommended that Housing Occupational Therapists approve plans for wheelchair homes prior to commencement of any building works and that plans submitted for approval should be in 1:50 except for separate kitchen, bath and shower room layouts which should be in 1:20.

The SE London Housing Partnership Wheelchair Homes Design Guidelines comply with (and generally exceed) 'Part M' of the Building Regulations, 'British Standard 8300', 'Lifetime Homes', the Housing Corporation 'Design and Quality Standards/Stephen Thorpe's 'Wheelchair Housing Design Guide' and the Mayor of London's Wheelchair Accessible Housing Guide.

Part M of the building regulations – is about **‘Visitability’** for people with disabilities and generally applies to ground floor access and access to a toilet in domestic dwellings. It does not provide full wheelchair accommodation.

British Standard 8300 (BS 8300) – is a good practice guide to improve design for people with a variety of disabilities.

‘Lifetime homes’ – were devised by the Joseph Rowntree Trust and cater for **a range of life needs from pram-pushing to using a walking frame** but the space afforded is insufficient to allow for the turn of a wheelchair in both the hall and the living areas. The standards would be adequate for occasional or part-time wheelchair use. They are recommended as the norm for ‘general needs’ housing.

‘Housing Corporation Design and Quality Standards (replaces Scheme Development Standards) – set **standards** which must be complied with for all homes receiving funding (Social Housing Grant) from the Homes and Communities Agency. For wheelchair homes the Housing Corporation Design and Quality Standards direct readers to: **‘Wheelchair housing design guide’** – by Stephen Thorpe which **offers guidance** to help meet the Housing Corporation Scheme Development Standards.

‘The Mayor of London’s Accessible Housing Guide’ has been produced to provide **advice** on how to implement the London Plan policy on wheelchair accessible housing. London Plan policy states that at least 10% of new homes should be designed to be wheelchair accessible or easily adaptable for residents who are wheelchair users.

Guide for housing associations and developers working in SE London - is produced by the SE London Housing Partnership and contains guidelines about development standards including reference to this publication.

Contents

Page

1. Moving around outside	6
2. Using outdoor spaces	7
3. Approaching the home	8
4. Negotiating the entrance door	9
5. Entering and leaving, dealing with callers	10
6. Negotiating the secondary door	11
7. Moving around inside/storing things	12
8. Moving between levels	12
9. Using living spaces	13
10. Using the kitchen	14, 15
11. Using the bathroom and shower room	16, 17, 18, 19
12. Using bedrooms	20
13. Operating doors	21
14. Operating windows	21
15. Controlling services	22, 23
Technical plans	24, 36
Appendices	37

1. Moving around outside

- 1.1 **Pavement crossovers:** Dropped kerbs 1000mm minimum width, sited in pairs opposite each other, gradient shall not exceed 1:12 with a slip resistant surface differing from that of pavement.
- 1.2 **Paths:** Width 1200mm, crossfalls must not exceed 1:50.
- 1.3 **Ramps:** Gradient 1:20, width 1200mm clear between handrails, 10 metres maximum length between resting platforms, non-slip surface, platforms at every change of direction and at door or gate 1500mm square or 1200mm x 1500mm.
- 1.4 **Protected edges:** 100mm kerb on paths and ramps.
- 1.5 **Rails:** Where there is a drop to the side of a path or ramp, midrail at 550mm and top rail 900mm extending 300mm horizontally beyond top and bottom ends of ramps. A protected edge is still required but may be part of the railing.

Ensure access for stretchers, average 610mm x 1550mm.

2. Using outdoor spaces

- 2.1 **Gate:** 900mm clear opening operable from both sides, not spring loaded.
- 2.2 **Approach space outside external door:** 1500mm x 1500mm platform extending 550mm from the lock side, and increased by the space used by an outward opening door, slip resistant surface with slight drainage falls.
- 2.3 **Clothes drying:** Accessible facilities, i.e. suitable for use from a wheelchair as described in section 1.
- 2.4 **Routes from external doors to storage, refuse and gate:** Shall be accessible and short (as described in section 1).
- 2.5 **Balconies:** Wheelchair accessible threshold, door 900mm clear opening, if double doors 1 leaf to be 900mm clear (Not Sliding doors). 1500mm min. turning circle unobstructed by door swing.

3. Approaching the home

- 3.1 **Car parking:** 4000 x 6600mm slip resistant level surface where possible covered, height 2300.
- 3.2 **Where car parking is behind automatic gates:** Hand held remote controls are required for disabled residents.
- 3.3 **Route to entrance:** Accessible as described in section 1 (covered if possible).
- 3.4 **Door canopy:** 1200 x 1500mm, height 2300mm extending beyond the door on the lock side 550mm.
- 3.5 **Lighting:** To car parking space, route to entrance and entrance itself, Passive Infra-Red (P.I.R.) detector and internal switching.
- 3.6 **Communal corridors:** Width access to wheelchair units to be min. 1200mm. If more than 1 wheelchair unit along a corridor then to be 1800mm wide to allow wheelchair users to pass or have passing places 1800mm wide and 1200mm long at reasonable intervals.
- 3.7 **Communal internal corridor doors** to be limited as far as possible. Where necessary to be type held open until released when fire alarm activated.
- 3.8 **Lifts:** Where wheelchair units have to be above ground floor, 2 wheelchair accessible lifts are required, with space for a wheelchair and at least one ambulant person.

4. Negotiating the entrance door, including communal doors

- 4.1 **Clear opening:** 900mm
- 4.2 **Approach space inside the external door:** 1800mm from the face of the door, and 1500mm wide. 550mm space to the lock side of the door..
- 4.3 **Threshold:** Weather tight with maximum 15mm bevelled upstand.
- 4.4 **Locks:** Deadlock height between 800 and 900mm, latch lock height between 900 and 1000mm with lever or easy grip handle. (Allow for 300mm rail for use as pull handle height between 800mm and 1000mm).
- 4.5 **Communal doors:** Shall be operable from a wheelchair. This will require mechanical assistance, remotely controlled. Maximum opening and closing force of doors should be 20 Newtons at the leading edge.
- 4.6 **Entry phone:** To communal front door to have table top handsets with 2m cable in the living room and bedroom. Kitchen handset to be wall fixed to avoid trailing cables.

5. Entering and leaving the home, dealing with callers

- 5.1 **A clear opening door:** 900mm.
- 5.2 **Approach space inside the front door:** Is essential for transfer to a second wheelchair 1800mm x 1500mm
- 5.3 **Threshold:** Weather tight with maximum 15mm bevelled upstand.
- 5.4 **Storing and charging for wheelchair:** To be near front door to limit transfer of dirt and water into the dwelling. Location of this space in the living or bedroom space is not acceptable. Maintain a 1500mm turning circle and provide a 1500mm x 1200mm charging space with power socket. Headroom minimum of 1200mm allows for understairs area to be used for this. The 1800mm x 1500mm space required in 5.1 can include the 1500mm turning circle required here if appropriate.
- 5.5 **Spyhole:** Height 1150mm centrally placed.
- 5.6 **Doorbell:** Height between 800 and 900mm, lock side of door.
- 5.7 **Letterbox:** Height 700mm with wire basket (not infringing on the 900mm clear opening).
- 5.8 **Entryphone:** See 4.6. Ensure locking mechanism to front doors is compatible with an entry phone.

6. Negotiating the secondary door

- 6.1 **External level landing:** 1500 x 1500mm and extend in length by 900mm if the door swings outwards.
- 6.2 **Clear 900mm door opening:** 550mm approach space to both sides of the door on the lock side, level weather-tight threshold as for front entrance door. (See 4.3)
- 6.3 **Secure lock or multi-locking:** Height between 800 and 1000mm for latches, pull handles, lever handles. Outward opening external doors require secure stays. The type of lock provided to allow for operation in conjunction with an overhead door opener. A minimum 120mm space above the doors to allow for a powered opener.
- 6.4 **External lighting:** To the door and en route with P.I.R. lighting and internal switching.
- 6.5 **French windows:** 900mm minimum clear opening on at least one of double doors. If used opening and locking to be possible one handed from a wheelchair.
- 6.6 **Sliding doors:** Shall not be used, rarely provide negotiable threshold.

7. Moving around inside/storing things

- 7.1 **All passageways:** Minimum 1200mm width clear of obstructions.
- 7.2 **Internal door openings:** Recommended clear opening 900mm (a minimum clear opening of 840mm is only acceptable if unavoidable), 550mm approach space to opening edge both inside and outside the room. No 2 leaf doors.
- 7.3 **Suitable storage:** Ensure depth and width of storage space in combination with any shelving layout provides optimum access to space and to stored items.

8. Moving between levels

- 8.1 **A vertical lift:** Is essential, positioned hall to landing, complying with BS 5900/1999. 1500mm turning circles are essential outside lift door on both levels clear of the door swing.
- 8.2 **The minimum internal lift:** Dimension required is 790mm wide, 1120mm long.
- 8.3 **Powered lift doors:** Are required.
- 8.4 **External lift controls:** To be accessible from a wheelchair.

9. Using living spaces

- 9.1 **Turning circle:** Each room shall have extra space for 1500mm turning circle clear of the door swing.
- 9.2 **Transfer spaces:** 1400mm is required in front of any furniture.
- 9.3 **Operable fittings:** Reaching heights between 800 and 1000mm.
- 9.4 **Radiators:** Shall not impede circulation.
- 9.5 **Sockets:** Shall be at least 750mm from a corner, height 800mm to top of socket plate.
- 9.6 **Light switches:** Full plate or large rocker light switches must be specified, height 900mm to top of switch plate.
- 9.7 **Hoists:** Ceiling shall be horizontal and have structural capacity for future possible hoist installation. The maximum weight load including equipment is 250kg.

The minimum ceiling height is 2000mm. The maximum ceiling height is 3650mm. See attached Appendix 3, page 37.

10. Using the kitchen

- 10.1 **Space and layout:** 1500mm turning circle plus room for another person i.e. 1800mm x 1500mm clear manoeuvring space.
- 10.2 **Worktop:** A continuous surface with knee recess is essential under and between hob and sink unit. Knee recess height 600mm. The work surface shall be adjustable, tiled behind, for heights from 700mm to 900mm. An 800mm wide section of adjustable height worktop with knee recess alongside the hob/sink section which can act as a work station. Fascia boards and vertical supports are to be avoided.
- 10.3 **Provide storage:** Appropriate to the size of dwelling (as set out in National Housing Federation 'Standards and Quality in Development: A Good Practice Guide'), the major proportion of which is in a position and format useable from a wheelchair. Wall units with pull down baskets should be provided when requested.
- 10.4 **Provide adjustable shallow sink:** With insulated bowl, reachable from a wheelchair, easily manipulated taps (e.g. short lever) and flexible plumbing, tiled behind, for heights from 700mm to 900mm.
- 10.5 **Provide adjustable hob:** Induction or ceramic hob with front or side controls, wall tiled behind to allow adjustment between 700mm and 900mm. Minimum of 300mm to each side of hob for pan handles, to be adjustable with the hob.

- 10.6 **Built in oven:** accessible from a wheelchair with reversible side hung door and non-tilt shelves. Heat resistant pull out shelf below oven. A 300mm worktop space to be available to the side of the oven on the opening side of the oven door.
- 10.7 **Additional space for appliances:** Is essential for people with disabilities, especially in smaller units (e.g. 4 spaces in a 1 or 2 person unit).
- 10.8 **All controls and socket outlets:** Shall be accessible. Provide remote and labelled switches for appliances and equipment. Switches shall be 150mm above maximum worktop level.
- 10.9 **Internal refuse:** If provided, arrangements shall be manageable from a wheelchair.
- 10.10 **300mm worktop space:** To be provided on the opening of the fridge door.

11. Using the bathroom and shower room

- 11.1 **Space for bath and shower:** Will vary between 1/2 bed dwellings and 3+ bed dwellings.
- 11.2 **1 and 2 bed dwellings:** Shall be provided with fully operational level access shower including all fittings. A bath shall be available on site and installed over the gully when necessary for individual tenants. This decision will be made at viewing. Where the dwelling has both a shower room and a bathroom the side transfer to WC to be on the left for one and on the right for the other.
- 11.3 **3 or more bed dwellings:** Shall have a fully operational bathroom and a fully operational shower room, each with WC and side transfer to WC to be on the left for one and on the right for the other.
- 11.4 **Bathroom and shower room:** Not to be en-suite unless secondary access from hall/corridor.
- 11.5 **Re: 11.2 and 11.3:** The Housing Corporation Guidelines require a shower gully to be available in every bathroom rather than under the bath. However, a gully with 1:40 falls in the centre of a bathroom floor makes the space harder to negotiate in a wheelchair. A useable shower 1200mm square in the corner of the room is required. 1:40 falls to the gully in the same corner. It is advisable to ensure a drainage fall across the whole floor.
- 11.6 **Turning circle:** Bath and/or shower rooms must each have 1500mm turning circle clear of the basin and WC.

- 11.7 **Transfer space to side:** Of WC pan, shower seat and bath must be 850mm from side edge; front edge of WC pan to rear wall must be 800mm unobstructed.
- 11.8 **Transfer space to front:** Of WC pan and shower seat must be 1100mm.
- 11.9 **Rail fitting space:** To wall side edge of WC pan and shower seat 250mm minimum and 350mm maximum.
- 11.10 **Hoist transfer space:** Between edge of WC pan and edge of bath must be a minimum of 850mm.
- 11.11 **Fixings** Structural capacity shall be provided in every bathroom and shower room for:
- ceiling track hoists (and ceiling shall be horizontal)
 - rails by WC
 - shower seat and rails
 - floor fixed equipment
 - over bath rails
- See Appendix A, page 37.
- 11.12 **WC height:** Should be standard i.e. 400mm pan.
- 11.13 **The cistern:** Must have a splayed lever handle on the outer/transfer side.
- 11.14 **Showering space:** Shall be at least 1200mm square.
- 11.15 **Level access shower:** Seat shall be on site and have drop-down legs, a back and drop-down arms and be height adjustable for fitting if required.

- 11.16 **Level access shower:** Controls shall be large and easy to see with anti-scald thermostatic control pre-set at a temperature of 43°C, 750mm from corner to edge of controls, height 1000mm.
- 11.17 **Level access shower:** Slider bar 1000mm long, 600mm from corner, lower height 1000mm on same wall as controls.
- 11.18 **Level access shower:** Hose 1500mm long.
- 11.19 **Rail with weighted shower curtain:** Required to contain water. The curtain shall fall to 15mm from finished floor level and enclose 1200mm square. Rail height to allow for ambulant use of the shower.
- 11.20 **Bath:** Must be standard i.e. height 520mm, width 700mm, length 1700mm, i.e. NOT A SHALLOW BATH.
- 11.21 **Bath taps:** Shall be short lever and fitted on the long outer or non-wall side and shall not hinder transfers.
- 11.22 **Integral bath rails:** Shall not protrude above the rim of the bath nor hinder transfers.
- 11.23 **Over bath shower:** Controls shall be large and easy to see with anti-scald thermostatic control pre-set at a temperature of 43°C. Position 750mm along the length of the bath from the tap end, height 1000mm from finished floor level.
- 11.24 **Over bath shower:** Slider bar 1000mm long located 900mm along the length of the bath from the tap end. Lower height 1000mm from finished floor level.

- 11.25 **Over bath shower:** Hose 1500mm long. If hair rinse shower then standard shorter hose required.
- 11.26 **Wash-hand basin:** Shall be non pedestal, cantilever, adjustable height with flexible plumbing and splashback tiled in advance for heights from 700mm to 1000mm. Taps must be short-lever.
- 11.27 **Rails:** 2 x 750mm dropdown rails, 2 x 600mm and 2 x 450mm pressalit type grabrails with slip resistant surface shall be available but NOT FITTED until tenant identified and assessed. Where a WC pan has been boxed off the wall a longer drop down rail 1000mm long shall be available. This list is not exhaustive.
- NB. Arrangements are required to be in place for installation of shower seat and rails as directed by an Occupational Therapist, prior to tenants moving into the property.
- 11.28 **Floor:** Shall be waterproof and slip resistant, sheet material (i.e. not tiles) extending up the wall by 150mm.
- 11.29 **Pull switches:** Shall have large pull, cord restraining eye and height 800mm.
- 11.30 **Shaving point:** Height between 800mm and 1000mm.
- 11.31 **Over basin light:** Shall have pull cord long enough to reach from a wheelchair.

12. Using bedrooms

- 12.1 **Turning circle:** All bedrooms shall have 1500mm turning circle clear of door swing.
- 12.2 **Transfer space:** To each side of double bed and one side of single beds shall be 1100mm.
- 12.3 **Access past bed:** A minimum of 1000mm between end of the bed and the wall, 1400mm if furniture opposite foot of bed.
- 12.4 **Access to furniture:** 1400mm is required between the bed and any other unit (e.g. wardrobes, chest of drawers, etc.).
- 12.5 **Controls:** Single bedrooms shall have 3 double socket outlets. Twin and double bedrooms shall have 4 double socket outlets. Sockets to be at least 750mm from a corner, height 800mm to top of socket plate.
- 12.6 **Adjacent to bedhead:** Shall have socket outlet, TV/FM points, entryphone point and 2 way light with pull cord over the bed.
- 12.7 **Hoists:** Ceiling shall be horizontal and have structural capacity in all bedrooms for future possible hoist installation.
- 12.8 **Hoist access:** Main bedroom to bathroom shall be connected by full height knock-out panel (required by Scheme Development Standards).

13. Operating doors

- 13.1 **Door construction:** Shall permit subsequent horizontal rail fitting at height between 800mm and 1000mm.
- 13.2 **Lever handles:** Height between 800mm and 1000mm.
- 13.3 **Internal locks:** Shall be easily manipulated inside and outside in emergencies, height between 800mm and 1000mm.
- 13.4 **Emergency opening:** Bathroom, shower room and WC doors shall open outwards.
- 13.5 **Self-closing doors:** Shall be operable independently from a wheelchair and have delayed action closing. Maximum opening and closing force of doors 15 Newtons at leading edge.

14. Operating windows

- 14.1 **Handles:** A single operating handle, height between 800mm and 1000mm shall be provided within reach for wheelchair user.
- 14.2 **Remote control:** Where window handle cannot be reached, install manual or powered window opening and locking gear within reach for wheelchair user.
- 14.3 **Safety:** Windows opening outwards shall not create hazards.
- 14.4 **Glazing line:** Shall not exceed height 800mm (except in kitchen and possibly bathroom).

15. Controlling services

- 15.1 **Main services:** Gas controls and electric consumer units shall be accessible for a wheelchair user at least 750mm from a corner, control height between 800 and 1100mm and seeing height 1200mm.
- 15.2 **Mains water:** Stopcock shall be accessible for a wheelchair user, at least 750mm from a corner, control height 800mm.
- 15.3 **Plumbing:** Isolating stop taps shall be provided for sink, washing machine, WC and shower, all reachable from a wheelchair.
- 15.4 **Flexible plumbing:** Shall be fitted to sink and wash-hand basins.
- 15.5 **Radiators:** Low Surface Temperature (LST) radiators shall be installed in all bathrooms and shower rooms and any other restricted areas.
- 15.6 **Light switches:** Full plate or large rocker light switches shall be specified, two way where required, height 900mm to top of switch plate.
- 15.7 **Pull light switches:** Shall have large pull, cord restraining eye and height 800mm.
- 15.8 **Socket outlets:** Shall have large switches on the outer ends of double sockets, at least 750mm from a corner, height 800mm from floor or 150mm above the maximum worktop level to the top of the socket.

- 15.9 **Socket outlets for appliances:** Socket 600mm where it is below worktop, with remote switch 100mm above maximum worktop level.
- 15.10 **Radiator controls:** Valves shall be 800mm height, easy to grip with 35mm clearance from wall.
- 15.11 **Central heating controls:** Boiler ignition, programmer, timer pump and thermostat shall all be at least 750mm from a corner, height 800mm and accessible for a wheelchair user.
- 15.12 **Telephone:** Provide a line with socket outlets, height 800mm in living-room, kitchen and bedrooms.
- 15.13 **Entryphone:** Provide an intercom and door opening system with handsets in bedrooms, living room and kitchen, position to be identified on plan. Table top version with 2 metre cable is required in living room and bedrooms. Kitchen handset to be wall fixed, height 800mm.

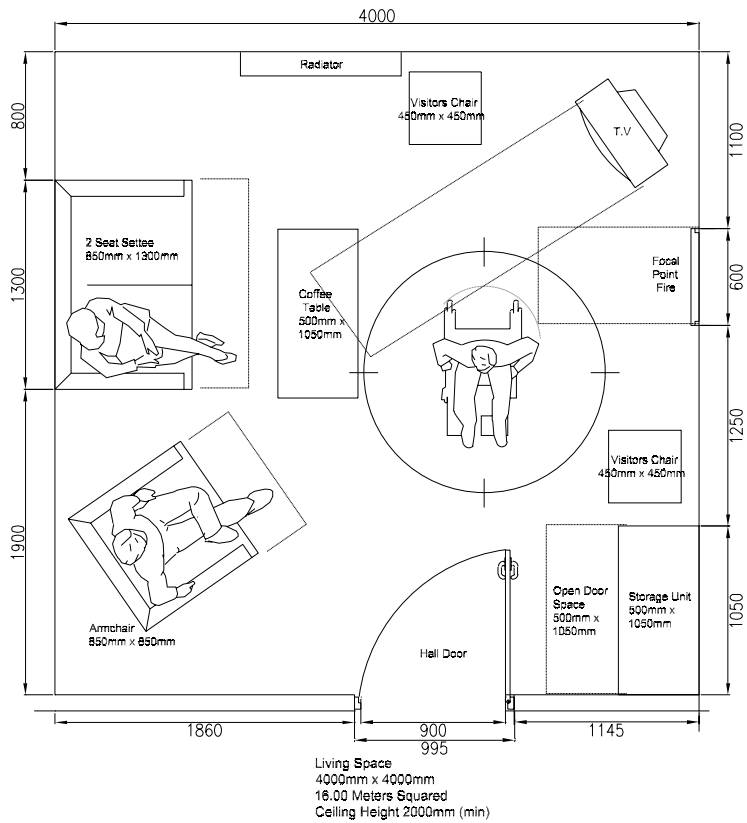

Lounge 1-3 person

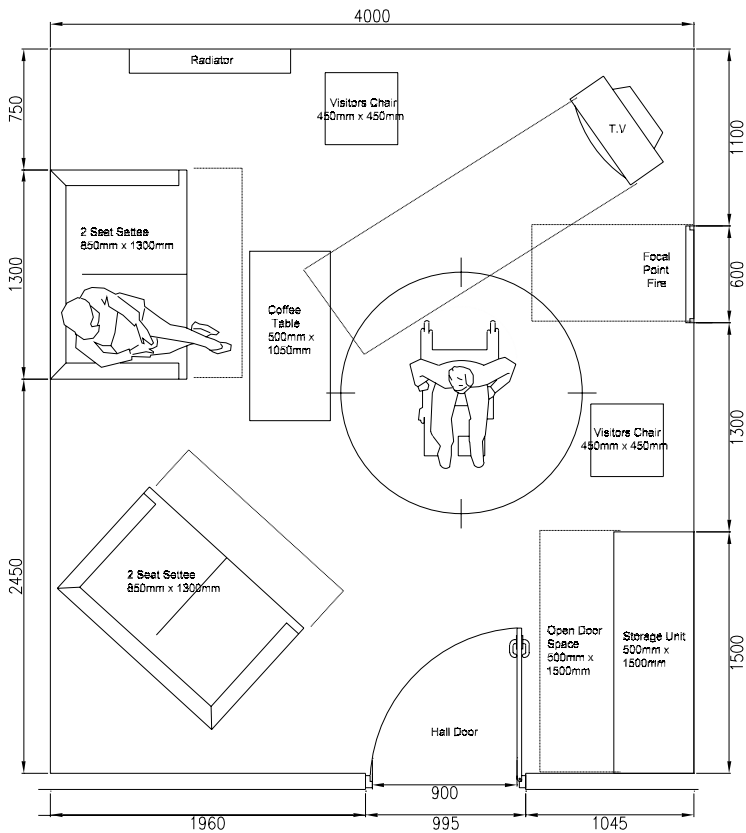

Living Space
 4000mm x 4500mm
 18.00 Meters Squared
 Ceiling Height 2000mm (min)

Lounge 4 person

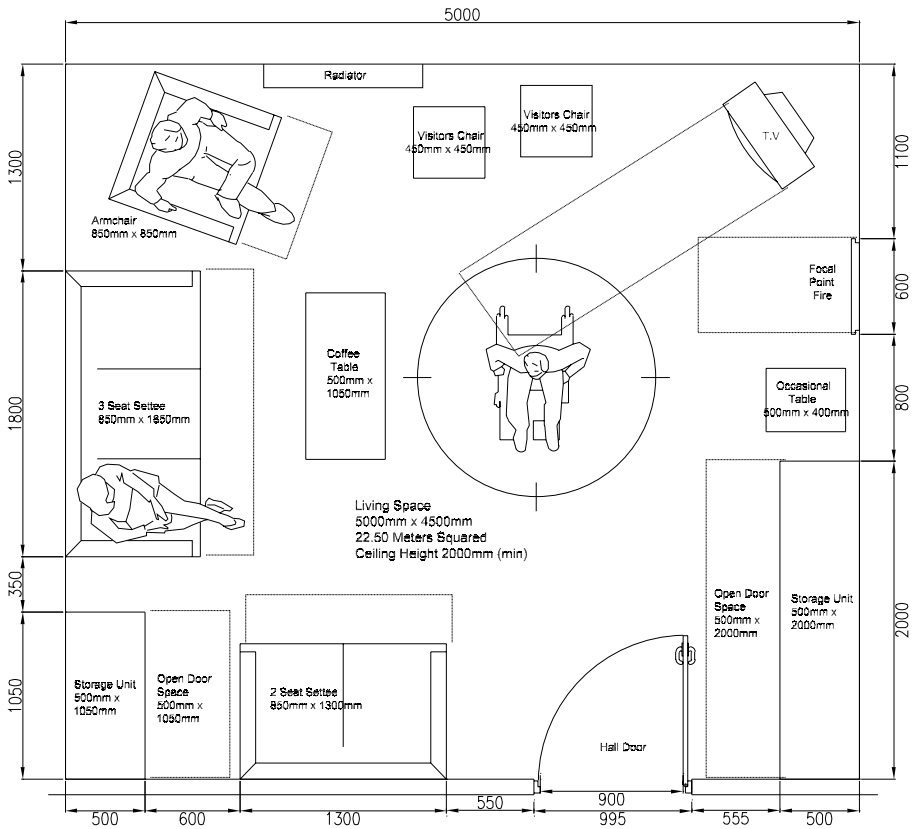

Lounge 5-6 person

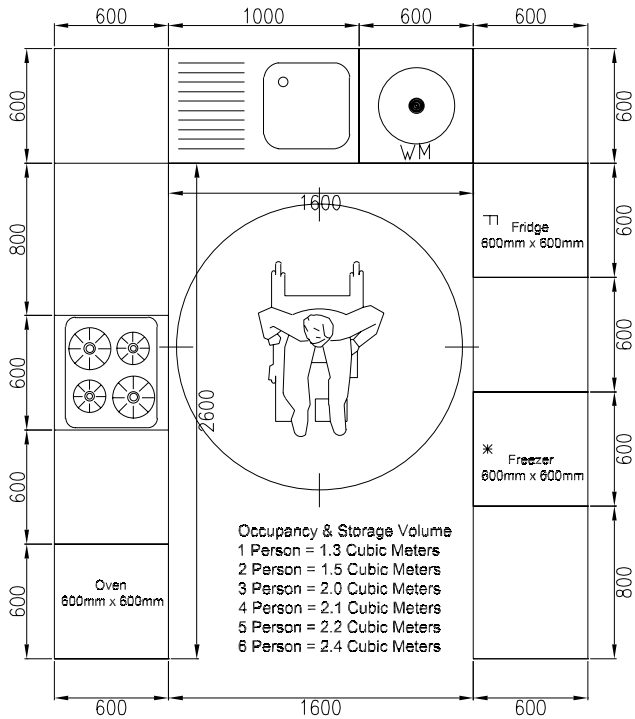

Kitchen
 3200mm x 2800mm
 8.96 Meters Squared
 Ceiling Height 2000mm (min)

Kitchen I-6 person

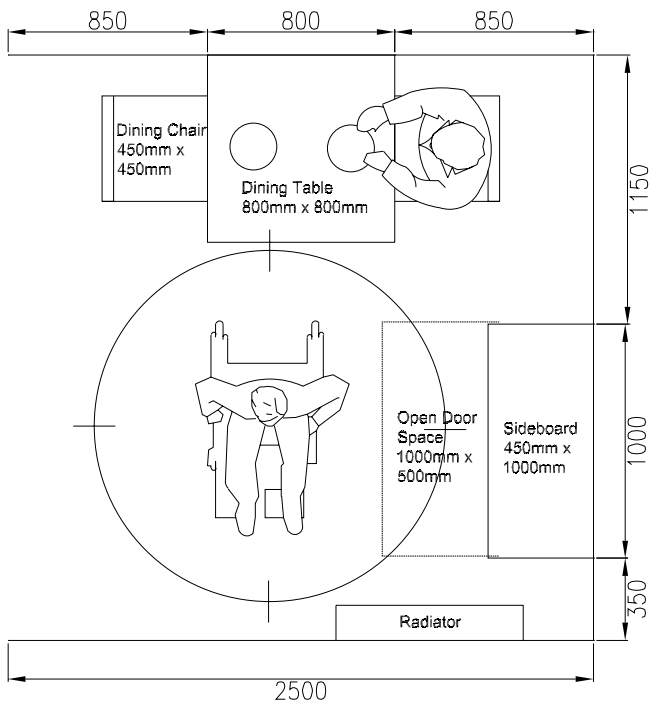

Dining Space
2500mm x 2500mm
6.25 Meters Squared
Ceiling Height 2000mm (min)

Dining space 1-3 person

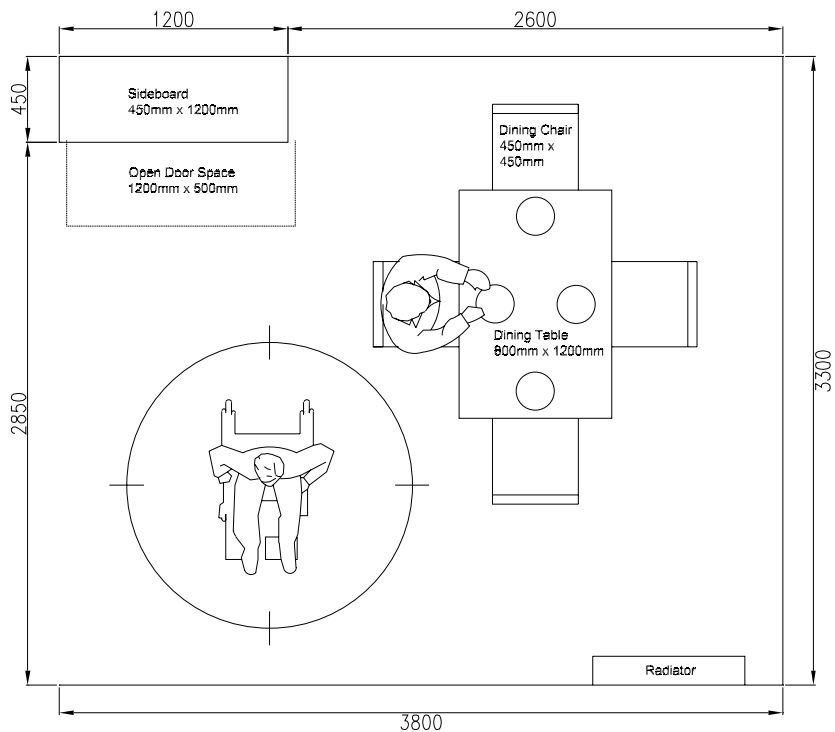

Dining Space
 3800mm x 3300mm
 12.54 Meters Squared
 Ceiling Height 2000mm (min)

Dining space 4 person

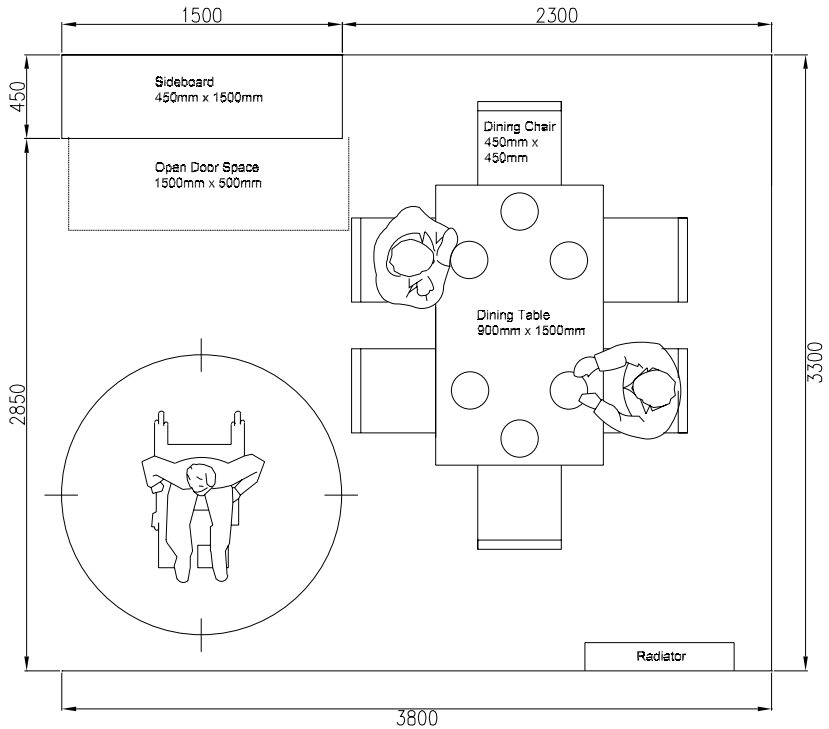

Dining Space
 3800mm x 3300mm
 12.54 Meters Squared
 Ceiling Height 2000mm (min)

Dining space 5-6 person

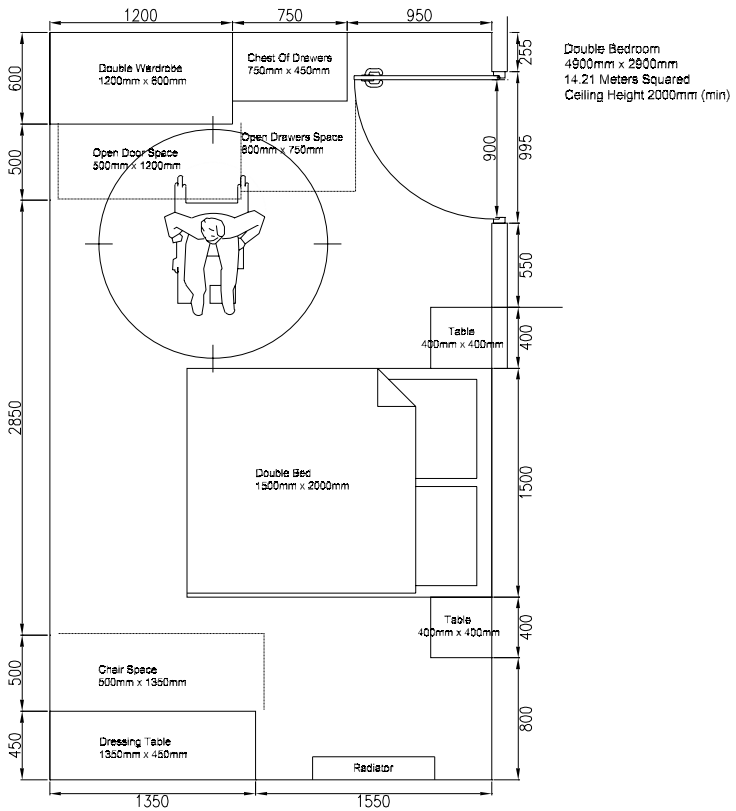

Double bedroom

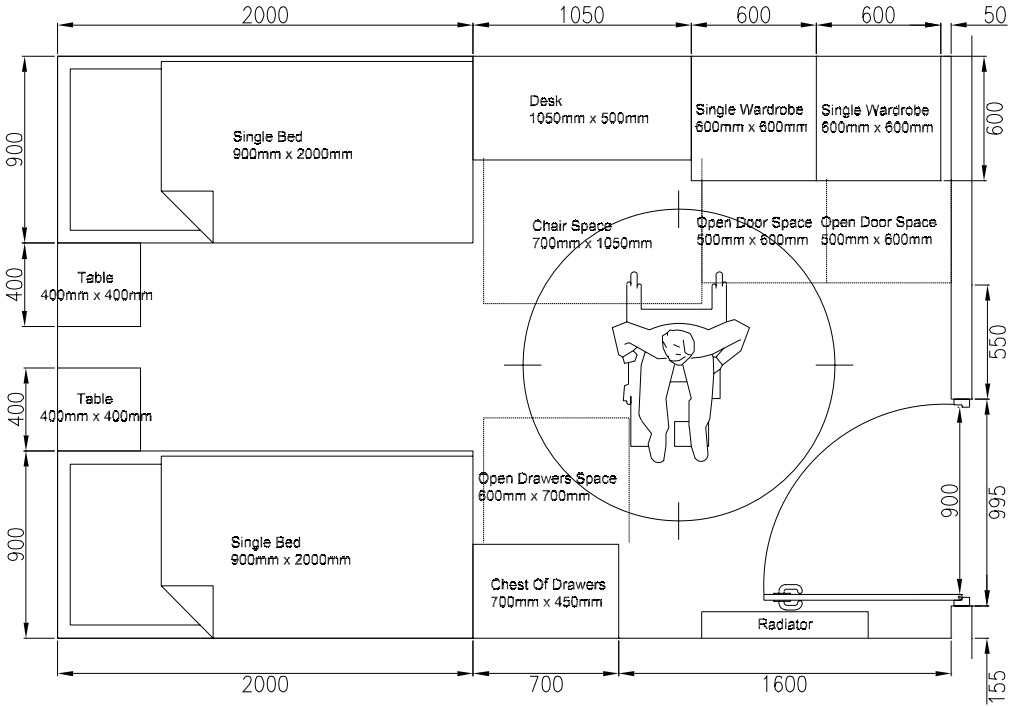

Twin Bedroom
 4300mm x 2800mm
 12.04 Meters Squared
 Ceiling Height 2000mm (min)

Twin bedroom

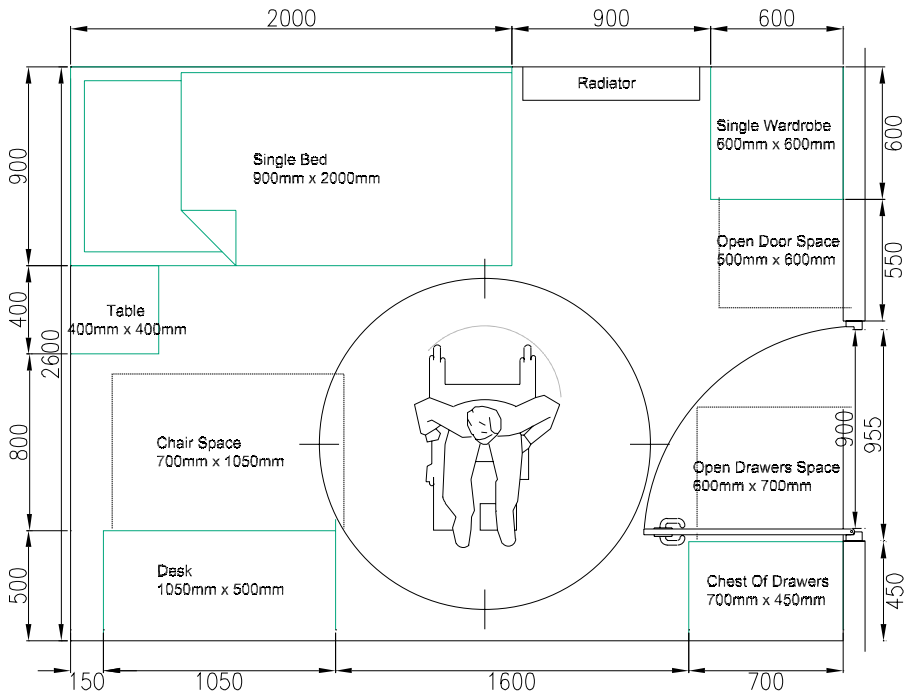

Single Bedroom
 3500mm x 2600mm
 9.10 Meters Squared
 Ceiling Height 2000mm (min)

Single bedroom

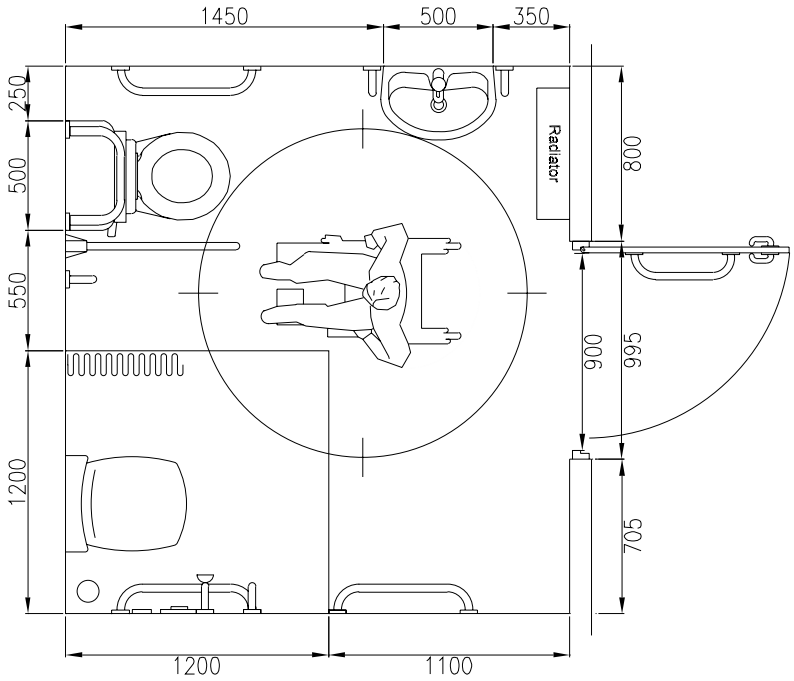

Shower Room:
 W.C/Shower/W.H.B/Radiator
 2300mm x 2500mm
 5.75 Meters Squared
 Ceiling Height 2000mm (min)

Shower room

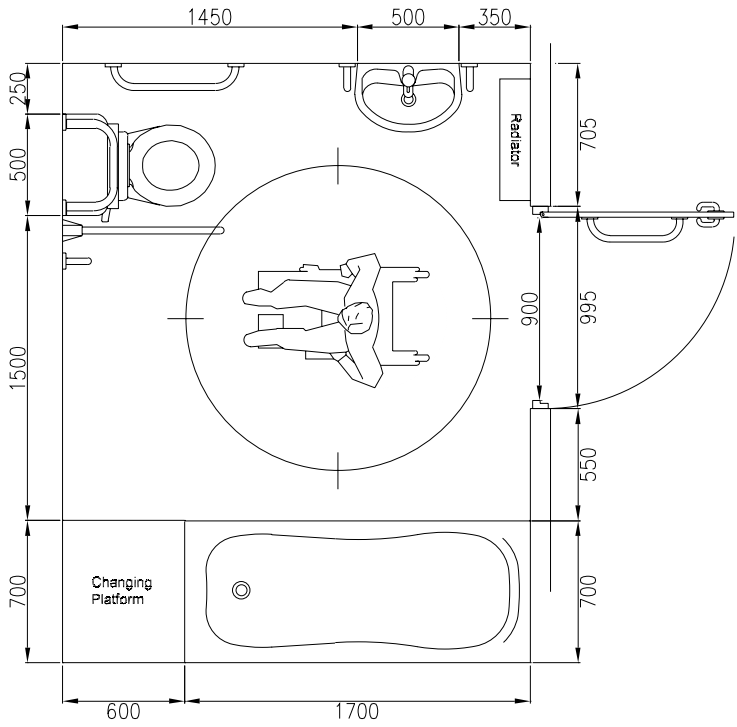

Bathroom: W.C/Bath/W.H.B/Radiator
 2300mm x 2950mm
 6.78 Meters Squared
 Ceiling Height 2000mm (min)

Bathroom

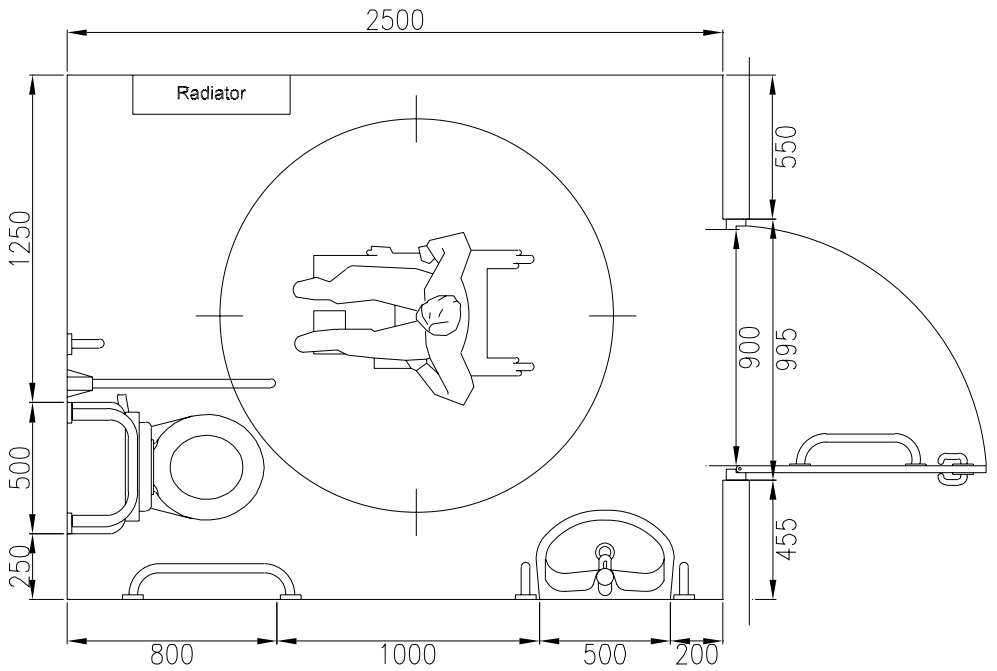

Bathroom: W.C/W.H.B/Radiator
 2000mm x 2500mm
 5.00
 Meters Squared
 Ceiling Height 2000mm (min)

Lavatory

Appendix A

Wall to the side of the WC to be strengthened up to min. height of 1500mm and min. 500mm in front of pan.

Wall behind WC strengthened to min. height of 1200mm and min. 500mm each side of cistern.

Wall behind basin strengthened to min. height 2000mm and min. 1200mm from corner enclosure.

Wall behind shower seat strengthened to min. height 150mm and min. 1200mm from corner of shower enclosure.

Appendix B

Calculations for ceiling track hoist

Calculation for hoist loadings should be based on the following:

Hoist unit weight	15kg
Hoist tracking	3kg per metre
Safe working load of the hoist is	150kg x 1.25 (Test load)
Maximum span of track between fixings is	900mm
Maximum distance of first fixing from end of track is	150mm

